

REMPLEUSEUR DE BARQUETTES

MOD. RPB4-F115

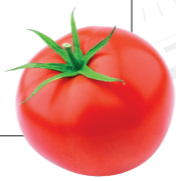

Remplisseur de barquettes mod. RPB4-F115

- Pour barquettes carton de 0,5 à 2kg
- Trémies pneumatiques.
- S'adapte en sortie de peseuses mod. W14-126A ou W12-126A.
- Structure en acier peint.
- Kit de protections aux Normes CE.

Riempitore di cestini mod. RPB4-F115

- Per vaschette di cartone da 0,5 a 2 kg
- Tramogge pneumatiche.
- Da addattare alle pesatrice mod. W14-126A o W12-126A.
- Struttura in acciaio verniciato.
- Kit di protezioni alle Norme CE.

Punnet filler mod. RPB4-F115

- For 0.5 to 2kg cardboard trays
- Pneumatic hoppers.
- To be connected with W14-126A or W12-126A weighing machines.
- Painted steel structure.
- CE compliant protection kit.

Llenador de cestas mod. RPB4-F115

- Para bandejas de cartón de 0,5 a 2 kg
- Tolvas neumáticas.
- A adaptar a la salida de las pesadoras mod. W14-126A o W12-126A.
- Estructura de acero pintado.
- Kit de protecciones a las Normas CE.

À PROPOS

**IDEAL POUR/IDEAL FOR
IDEALE PER/IDEAL PARA**

**PRODUCTION/OUTPUT
PRODUZIONE/PRODUCCIÓN**

- 70-80 conf/min (en fonction des dimensions de la barquette)
- 70-80 conf/min (depending on tray size)
- 70-80 conf/min (a seconda delle dimensioni del vassoio)
- 70-80 conf/min (a seconda delle dimensioni del vassoio)

**PUISSANCE ELECTRIQUE/ELECTRIC POWER
POTENZA ELETTRICA/ POTENCIA ELÉCTRICA**

- Sans dépileurs : 13kW - 400V - (3P+T+N)
- Avec dépileurs : 15kW - 400V - (3P+T+N)

**CONSOMMATION D'AIR/AIR CONSUMPTION
CONSUMO ARIA/CONSO DE AIRE**

10,78m3/heure (à 6 bar)

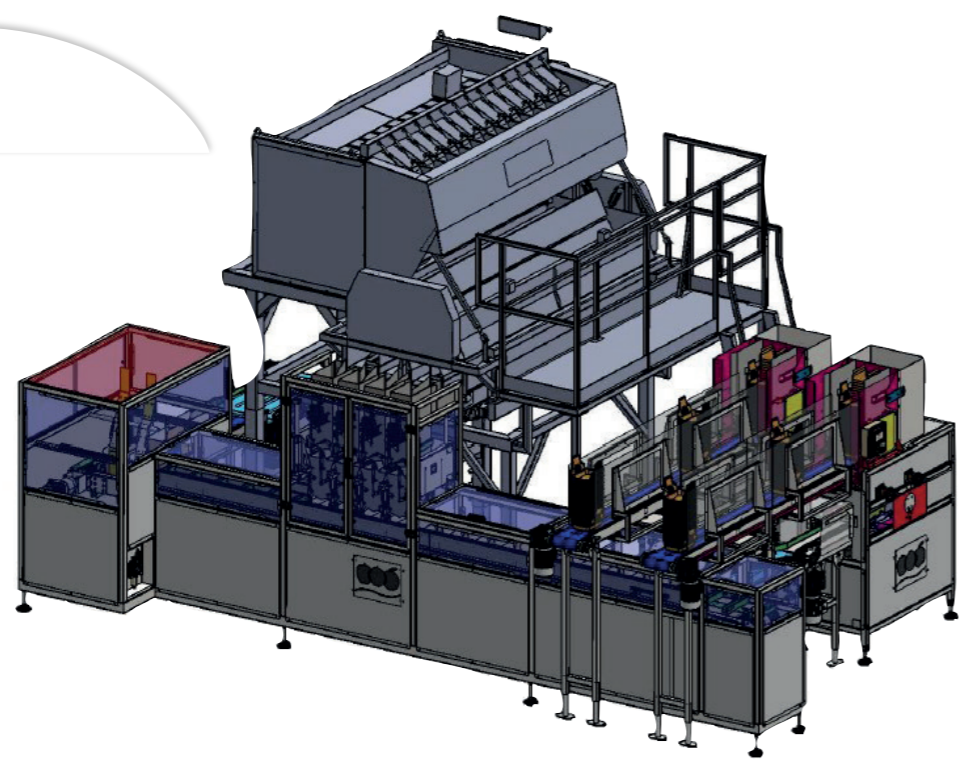
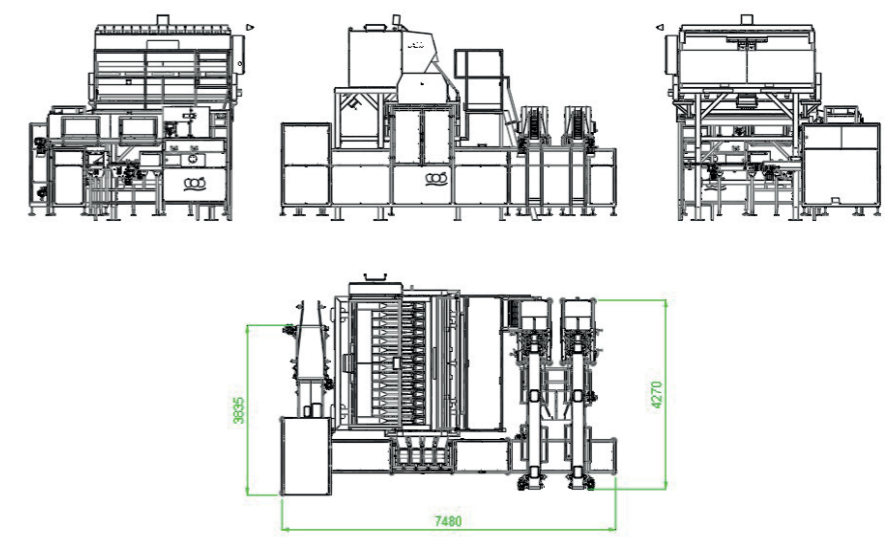

Siège social : SORMAF Sarl - 84300 Cavailon
04 90 71 21 94 sormaf@sormaf.fr

