

DEIMPILATORE PEDANE DPP-108



DEIMPILATORE PEDANE mod. DPP-108

Il DPP-108 è un Deimpilatore Alimentatore di pedane di diversi formati, adatto ad alimentare pedane vuote impilate a qualsiasi palettizzatore Sorma.

Il DPP-108 può essere alimentato da carrelli elevatori o transpallet a mano.

Si possono caricare fino a 20 pedane per ogni vano di caricamento, a seconda del formato.

PALLET DESTACKER mod. DPP-108

The machine mod. DPP-108 is a Destacker-Feeder for pallets of different sizes, suitable to feed empty stacked pallets to any Sorma palletiser.

It can be fed by lifting trolleys or transpallets (by hand).

It is possible to load up to 20 pallets for each loading compartment depending on pallets size.

DESEMPILEUR-ALIMENTATEUR mod. DPP-108

La machine mod. DPP-108 est un Désempileur- Alimentateur de palettes de différents formats; elle permet d'alimenter de palettes empilées vides à n'importe quel palettiseur Sorma.

Le désempileur peut être alimenté par des chariots élévateurs ou par des transpallets (manuellement).

Il est possible de charger jusqu'à 20 palettes pour chaque compartiment de chargement selon le format des palettes.

DATI TECNICI/TECHNICAL DATA

POTENZA ELETTRICA INSTALLATA
INSTALLED POWER
PUISSANCE ELECTRIQUE INSTALLÉE
ANSCHLUSSWERT ELEKTR
POTENCIA ELÉCTRICA INSTALADA
Установленная мощность

1,5 kW - 50 Hz - 400 V

CONSUMO ARIA
AIR CONSUMPTION
CONSOMMATION D'AIR
LUFTVERBRAUCH
CONSUMO DE AIRE
Потребление воздуха

5 NI/min - 6 bar

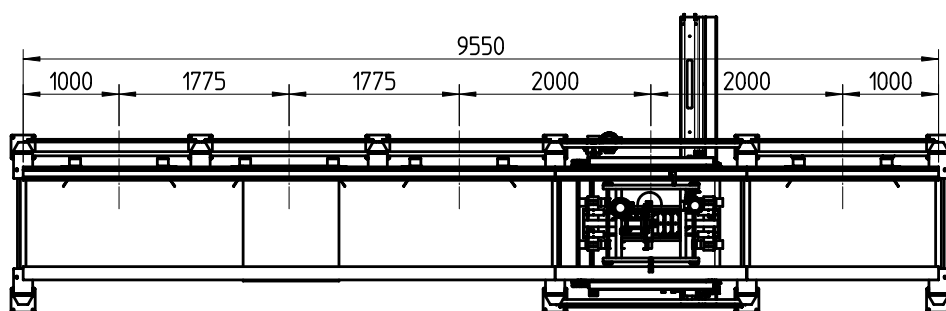
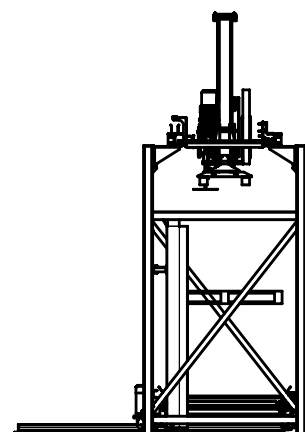
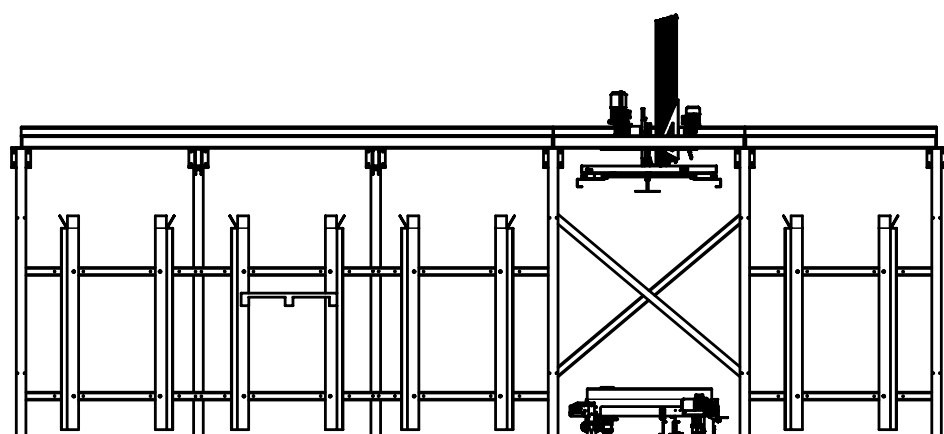

DEIMPILATORE PEDANE DPP-108

AGENTE DI ZONA / LOCAL DEALER



SORMA S.p.A.

via Delle Mele, 65 - 47522 Cesena (FC) - ITALY
Tel. (+39) 0547 418611 - Fax. (+39) 0547 418612
sorma@sormaitalia.com - www.sormagroup.com